

# NCS Series



Non-waterproof

RoHS

Safety standard certified products available

## Overview

- Basic type of round metal connectors.
- Representative series that has proven performance in various indoor manufacturing equipment over a long period of time.
- High resistance to starting current and load current, enabling these connectors active in various manufacturing equipment.

## Feature

RoHS	RoHS Directive compliant
Waterproof	Non
Lock method	Thread lock
Features of mechanism/ material	<ul style="list-style-type: none"> <li>○ Simple structure, easy handling and robust.</li> <li>○ Ten shell sizes and many connector shapes available for a wide variety of applications.</li> </ul>
Standards	<ul style="list-style-type: none"> <li>○ &lt; CSA NRTL/C &gt; standard certified connectors available. ( CSA : C22.2 No.182.3 UL : 1977 )</li> </ul> <p><small>Note: The specifications of safety standard certified connectors are slightly different from those of standard products. For the rated voltage, current and cable conductor cross sectional area, refer to A List of Standards Acquired ( p.129 ).</small></p>
Cable termination	Soldering

## Characteristics

Insulation resistance , Withstand voltage , Contact resistance p.10



The pin contact type has an **exposed electrode**. If it is used on the [ power supply ] side, it may cause **electric shock** or **short-circuit accidents**. To prevent such accidents, use the socket contact type on the [ power supply ] side and the pin contact type on the [ equipment ] side.

[ When inserting or extracting the connector, do not turn the connector body. ]

# NCS Series

## Product No. designation

**NCS - 25 ■ - P M**

①      ②      ③      ④      ⑤      ⑥      ⑦

- ① Series designation
- ② Shell size
- ③ Number of contacts
- ④ Shell shape
- ⑤ Contact shape < Pin (male) contact : M, Socket (female) contact : F >  
The S Type of NCS Series in all shapes of PF, RM, AdM, etc. is indicated simply by P, R, Ad, etc. with the contact shape symbol omitted.
- ⑥ Additional symbol (-CH) 《 Required only for Shell size 16 》
- ⑦ Safty standard specification( < CSA NRTL/C > )  
 《 Required only when safty standard is to be specified. 》 For applicable products, see p.129.

## Cable termination : Soldering

## Material and Finish

	Material	Finish
Shell	Zinc alloy or brass (partially aluminum alloy)	Chrome plating Special treatment Tin-cobalt plating ( Shell size 16 only )
Insulator	Synthetic resin	—
Contact	Copper alloy	Shell size 14 , 16 , 25 , 30 : Nickel plating Shell size 40 , 44 , 50 , 54 , 60 , 64 : Silver plating Shell size 30 ( Number of contacts 7H , 13 ) : Gold plating

## Temperature tolerance level

-40°C to +120°C

## Exclusive tools ( optional ) : Contact wrench, soldering iron tip set

The contacts of rated current 80 A or over are constructed for removal from the insulator.  
 For soldering, remove the contact with a contact wrench.

### 《 Types of contact wrenches 》



**80A Contact Wrench**

Used for:

- NCS · NWPC-502 / 542
- NCS · NWPC-503 / 543
- NCS · NWPC-604 / 644



**150A Contact Wrench**

Used for:

- NCS · NWPC-602 / 642
- NCS · NWPC-603 / 643

### 《 Soldering iron tip set 》

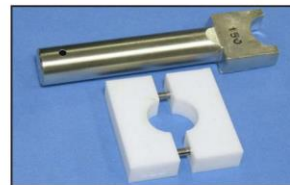

Usable soldering iron 200 W  
 Iron tip inserting diameter  $\phi$  16 mm or over  
 Iron tip temperature setting 420°C to 450°C

Set name \* A set of iron tip and heat insulator.

For 80A contact → SS80-KB

For 150A contact → SS150-KB

They are also available individually.

For 80A contact

【 Iron tip → SS80-K 】 【 Heat insulator → SS80-B 】

For 150A contact

【 Iron tip → SS150-K 】 【 Heat insulator → SS150-B 】

### 【 80A Contact Wrench, 150A Contact Wrench 】

One tool is usable for installation and removal of a male and female contact.

# NCS Series Characteristics

Shell size	Contact	Insulation resistance ( M Ω )		Contact resistance ( m Ω )		Withstand voltage ( V r.m.s. )		
		S Type	G Type	S Type	G Type	S Type	G Type	
		Number of contacts						
14	1	DC 500V	—	3	—	1,000	—	
	2	2,000 min.		max.				
16	1	DC 500V 2,000 min.	—	3 max.	3 max.	1,000	1,000	
	2		DC 500V					
	3		2,000 min.					
	4		—					
25	2	DC 1,000V 2,000 min.	DC 1,000V 2,000 min.	3 max.	3 max.	2,000	2,000	
	3							
	4							
	5							
	6					1,800	1,800	
	7							
30	2	DC 1,000V 2,000 min.	DC 1,000V 2,000 min.	3 max.	3 max.	2,000	2,000	
	3							
	4							
	5							
	6					DC 500V 2,000 min.	1,800	1,800
	7					—	—	—
	8					DC 1,000V 2,000 min.	1,800	1,800
	7H 13					DC 500V 2,000 min.	—	—
40 (S Type)	2	DC 1,000V 2,000 min.	DC 1,000V 2,000 min.	3 max.	3 max.	2,500	2,500	
	3							
	4							
	5							
	6					2,000	2,000	
44 (G Type)	8	DC 1,000V 2,000 min.	DC 1,000V 2,000 min.	3 max.	3 max.	1,800	1,800	
	10							
	12							
	16							
	20							

Shell size	Contact	Insulation resistance ( M Ω )		Contact resistance ( m Ω )		Withstand voltage ( V r.m.s. )		
		S Type	G Type	S Type	G Type	S Type	G Type	
		Number of contacts						
50 (S Type)	2	DC 1,000V	DC 1,000V	1	1	3,000	3,000	
	3	5,000 min.	5,000 min.	max.	max.			
	4					2,500	2,500	
	54 (G Type)	8	DC 1,000V 2,000 min.	DC 1,000V 2,000 min.	3 max.	3 max.	2,000	2,000
		10						
15								
25		1,800						
60	2	DC 1,000V 5,000 min.	—	1 max.	—	3,000	—	
	3							
	4							
	10							2,500
	15	DC 1,000V 2,000 min.	DC 1,000V 2,000 min.	3 max.	3 max.	1,800	1,500	
	30							
	32							
	40							—
64	2	—	DC 1,000V 5,000 min.	—	1 max.	—	3,000	
	3							
	4							

■ includes safety standard certified products.

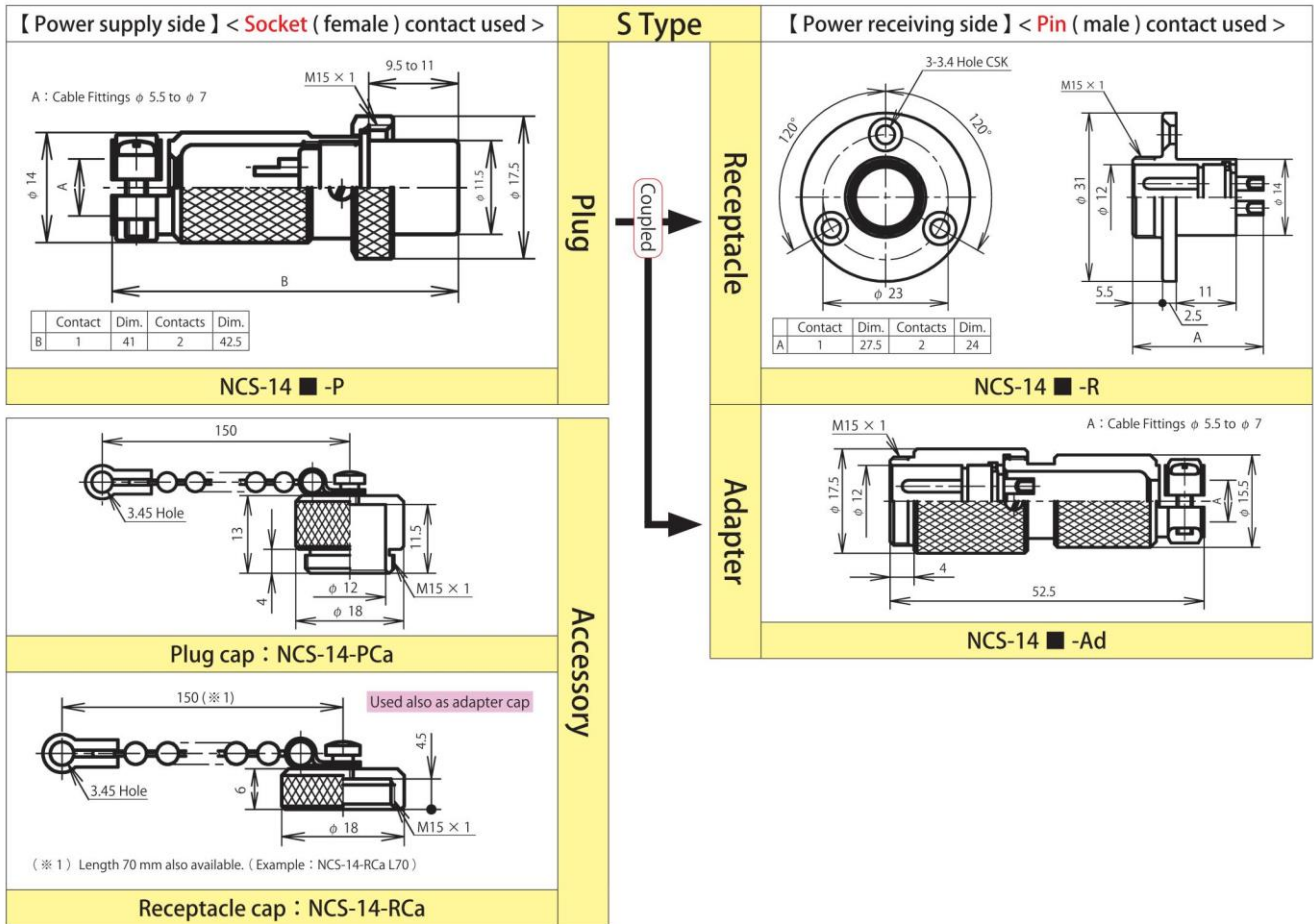

■ indicates the number of contacts. The conductor cross sectional area is less than the following value.

Shell size	Number of Contacts	1	2
14	Contact arrangement <When viewed from the pin (male) contact coupling side>		
	Safety standard	—	
	Rating	125V 5A	
	Limit operating voltage (Note-1)	200V	
	Withstand voltage (V r.m.s.)	1,000	
	Wire size (mm <sup>2</sup> )	0.75	

Note-1 : For the limit operating voltage, see p.131.

# NCS Series Shell Size 16

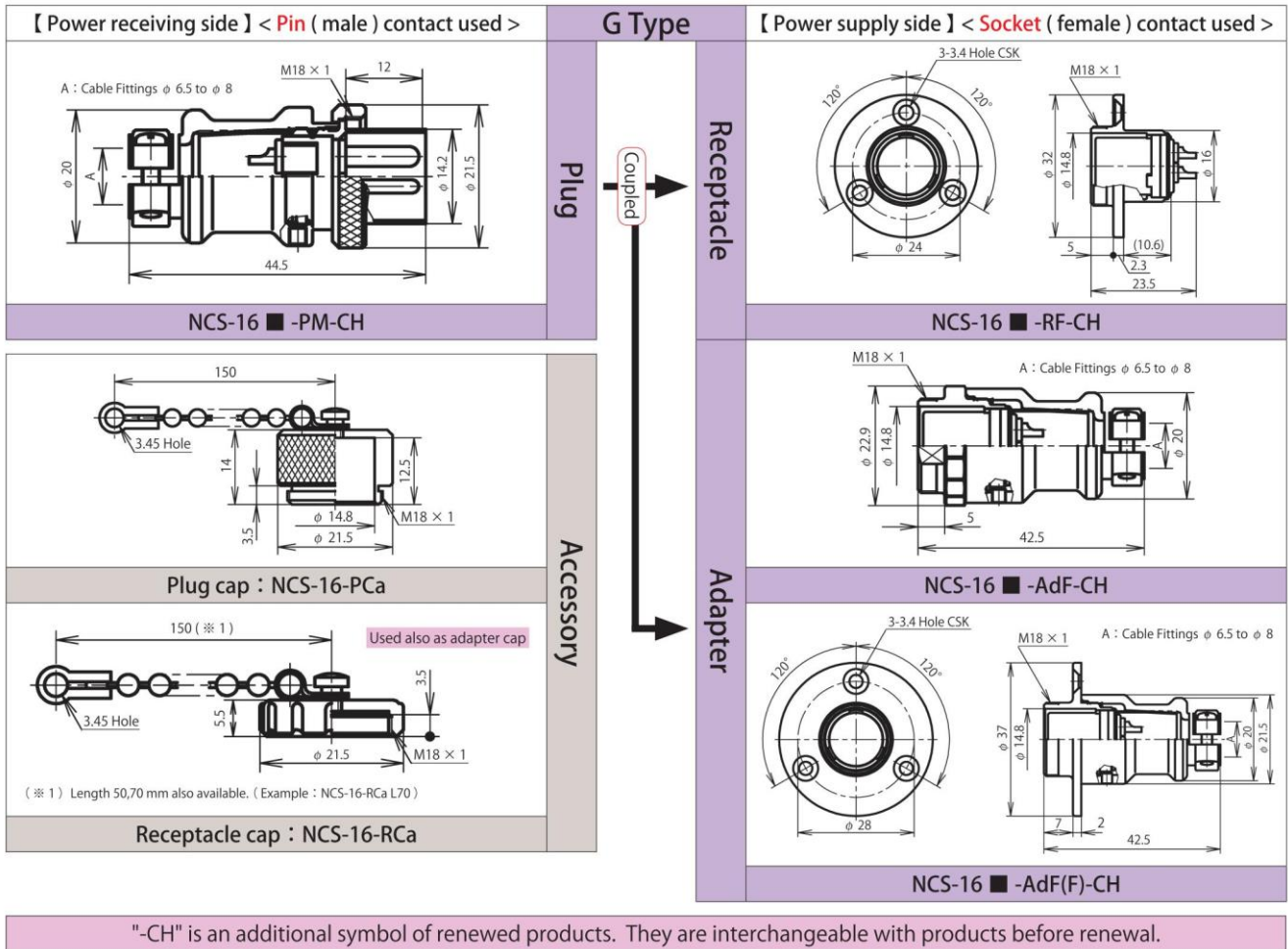

"-CH" is an additional symbol of renewed products. They are interchangeable with products before renewal.

■ indicates the number of contacts. The conductor cross sectional area is less than the following value.

Shell size	Number of Contacts	2	3
16	Contact arrangement <When viewed from the pin (male) contact coupling side>		
	Safety standard	—	
	Rating	125V 5A	
	Limit operating voltage (Note-1)	200V	
	Withstand voltage (V r.m.s.)	1,000	
Wire size (mm <sup>2</sup> )	0.75		

Note-1 : For the limit operating voltage, see p.131.

# NCS Series Shell Size 16

NCS

16

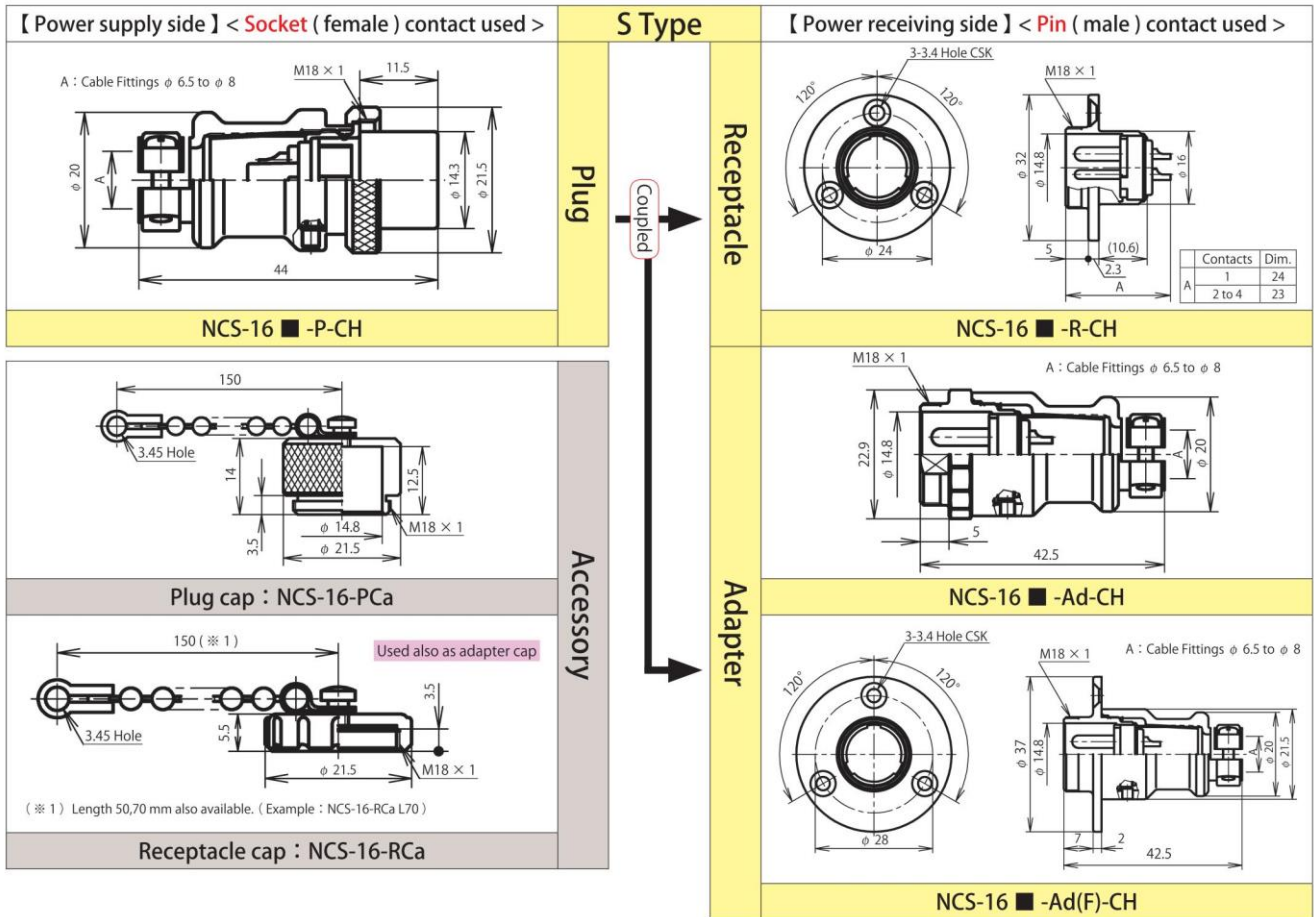

"-CH" is an additional symbol of renewed products. They are interchangeable with products before renewal.

■ indicates the number of contacts. The conductor cross sectional area is less than the following value.

Shell size	Number of Contacts	1	2	3	4
16	Contact arrangement <When viewed from the pin (male) contact coupling side>				
	Safety standard	—			
	Rating	125V 10A	125V 5A		
	Limit operating voltage (Note-1)	200V			
	Withstand voltage (V r.m.s.)	1,000			
	Wire size (mm <sup>2</sup> )	1.25	0.75		

Note-1 : For the limit operating voltage, see p.131.

# NCS Series Shell Size 25

**【 Power receiving side 】 < Pin ( male ) contact used >**

**NCS-25 ■ -PM**

**NCS-25 ■ -GPM 1/2 ( Note )**

**NCS-25 ■ -SPM**

**NCS-25 ■ -LPM**

**Plug cap : NCS-25-PCa**

**G Type**

**Receptacle**

**Adapter**

**Accessory**

**【 Power supply side 】 < Socket ( female ) contact used >**

**NCS-25 ■ -RF**

**NCS-25 ■ -RF kaku**

**NCS-25 ■ -AdF**

**NCS-25 ■ -AdF(F)**

**NCS-25 ■ -GAdF1/2 ( Note )**

**Receptacle cap : NCS-25-RCa**

Note: We show sizes by the nominal "G(PF)" of parallel pipe threads. p.135

■ indicates the number of contacts.

The conductor cross sectional area is less than the following value. However, for safety standard certified products, use a cable having a value shown on p.129.

Shell size	Number of Contacts	2	3	4	5	6	7
25	Contact arrangement <When viewed from the pin (male) contact coupling side>						
	Safety standard (Note-1)	—				CSA NRTL/C	
	Rating	250V 10A				250V 5A	
	Limit operating voltage (Note-2)	400V				300V	
	Withstand voltage (V r.m.s.)	2,000				1,800	
Wire size (mm <sup>2</sup> )	2				1.25		



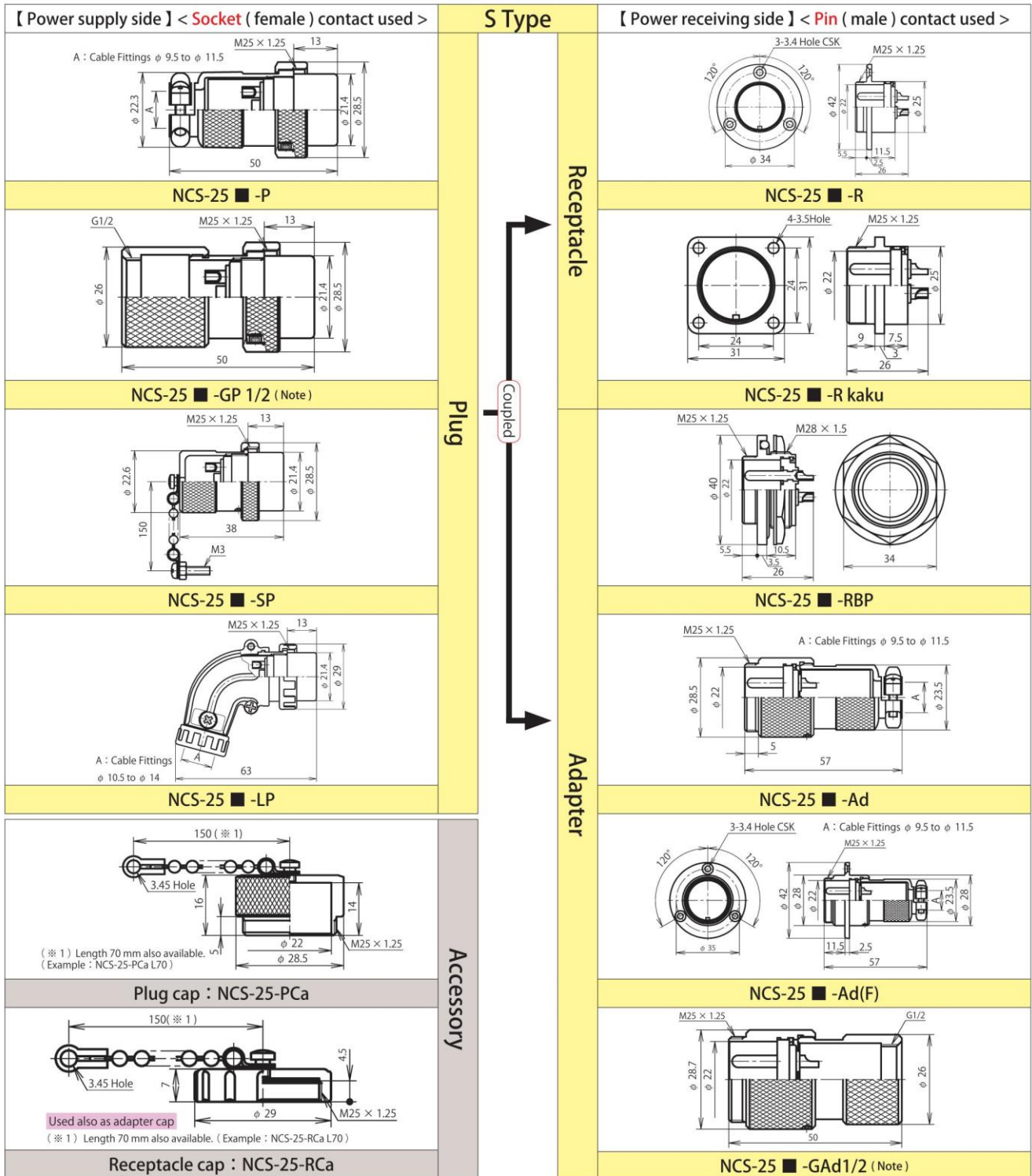



Note-1 : Specified separately. For safety standards, see p.129. (The rated voltage of standard certified products is 265 V.) Note-2: For the limit operating voltage, see p.131.



Note: We show sizes by the nominal "G(PF)" of parallel pipe threads. P.135

■ indicates the number of contacts.

The conductor cross sectional area is less than the following value. However, for safety standard certified products, use a cable having a value shown on p.129.

Shell size	Number of Contacts	2	3	4	5	6	7	8	
25	Contact arrangement <When viewed from the pin (male) contact coupling side>								
	Safety standard (Note-1)	—				CSA NRTL/C		—	
	Rating	250V 10A						250V 5A	
	Limit operating voltage (Note-2)	400V				300V			
	Withstand voltage (V r.m.s.)	2,000				1,800			
Wire size (mm <sup>2</sup> )	2							1.25	

Note-1 : Specified separately. For safety standards, see p.129. (The rated voltage of standard certified products is 265 V.) Note-2 : For the limit operating voltage, see p.131.



# NCS Series Shell Size 30

NCS

30

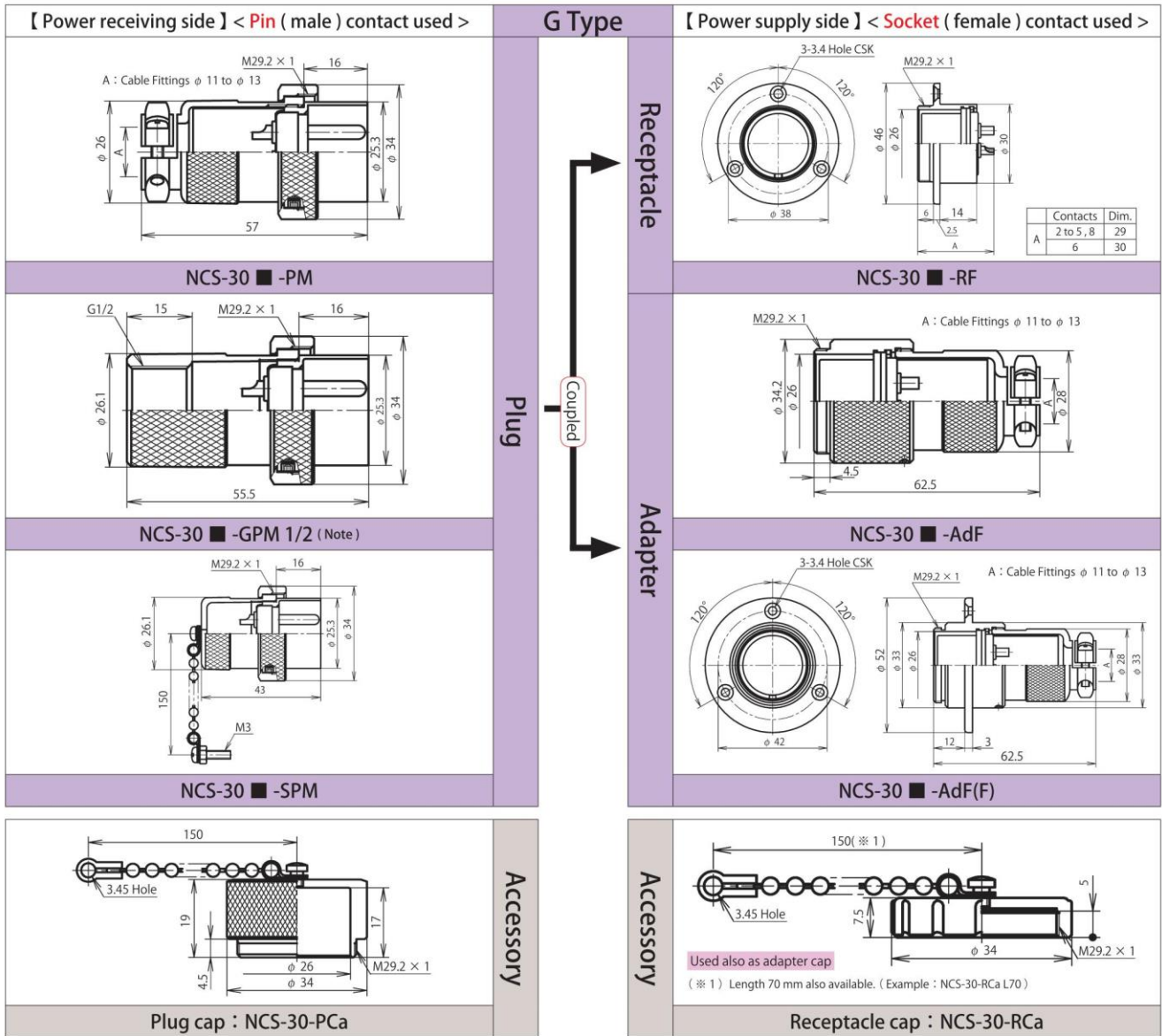

Note: We show sizes by the nominal "G(PF)" of parallel pipe threads. p.135

■ indicates the number of contacts.  
The conductor cross sectional area is less than the following value. However, for safety standard certified products, use a cable having a value shown on p.129.

Shell size	Number of Contacts	2	3	4	5	6	8
30	Contact arrangement <When viewed from the pin (male) contact coupling side>						
	Safety standard (Note-1)	—	CSA NRTL/C	—	—	—	CSA NRTL/C
	Rating	250V 15A			250V 10A		250V 5A
	Limit operating voltage (Note-2)	400V			—		300V
	Withstand voltage (V r.m.s.)	2,000			1,800		—
Wire size (mm <sup>2</sup> )	—			2		1.25	

Note-1 : Specified separately. For safety standards, see p.129. (The rated voltage of standard certified products is 265 V.) Note-2: For the limit operating voltage, see p.131.

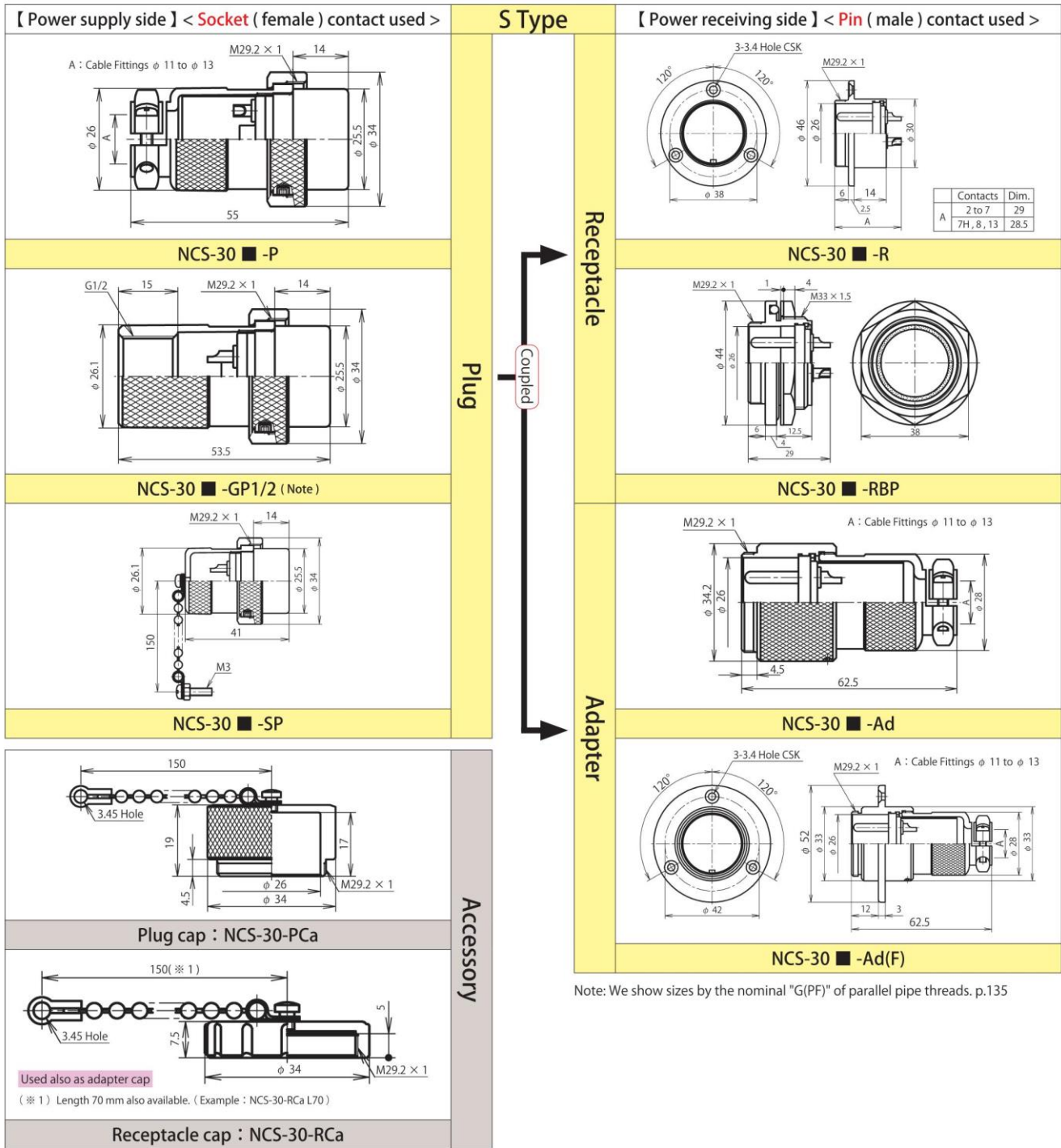

■ indicates the number of contacts.

The conductor cross sectional area is less than the following value. However, for safety standard certified products, use a cable having a value shown on p.129.

[ ] : Gold plating contact

Shell size	Number of Contacts	2	3	4	5	6	7	7H	8	13
30	Contact arrangement <When viewed from the pin (male) contact coupling side>									
	Safety standard (Note-1)	—	CSA NRTL/C	—	—	—	—	—	CSA NRTL/C	—
	Rating	250V 15A						250V[ 7A ]	250V10A	250V[ 5A ]
	Limit operating voltage (Note-2)	400V						—	300V	—
	Withstand voltage (V r.m.s.)	2,000			1,800			1,500	1,800	1,500
Wire size (mm <sup>2</sup> )	3.5	—			2		1.25	2	1.25	

Note-1 : Specified separately. For safety standards, see p.129. (The rated voltage of standard certified products is 265 V.) Note-2 : For the limit operating voltage, see p.131.

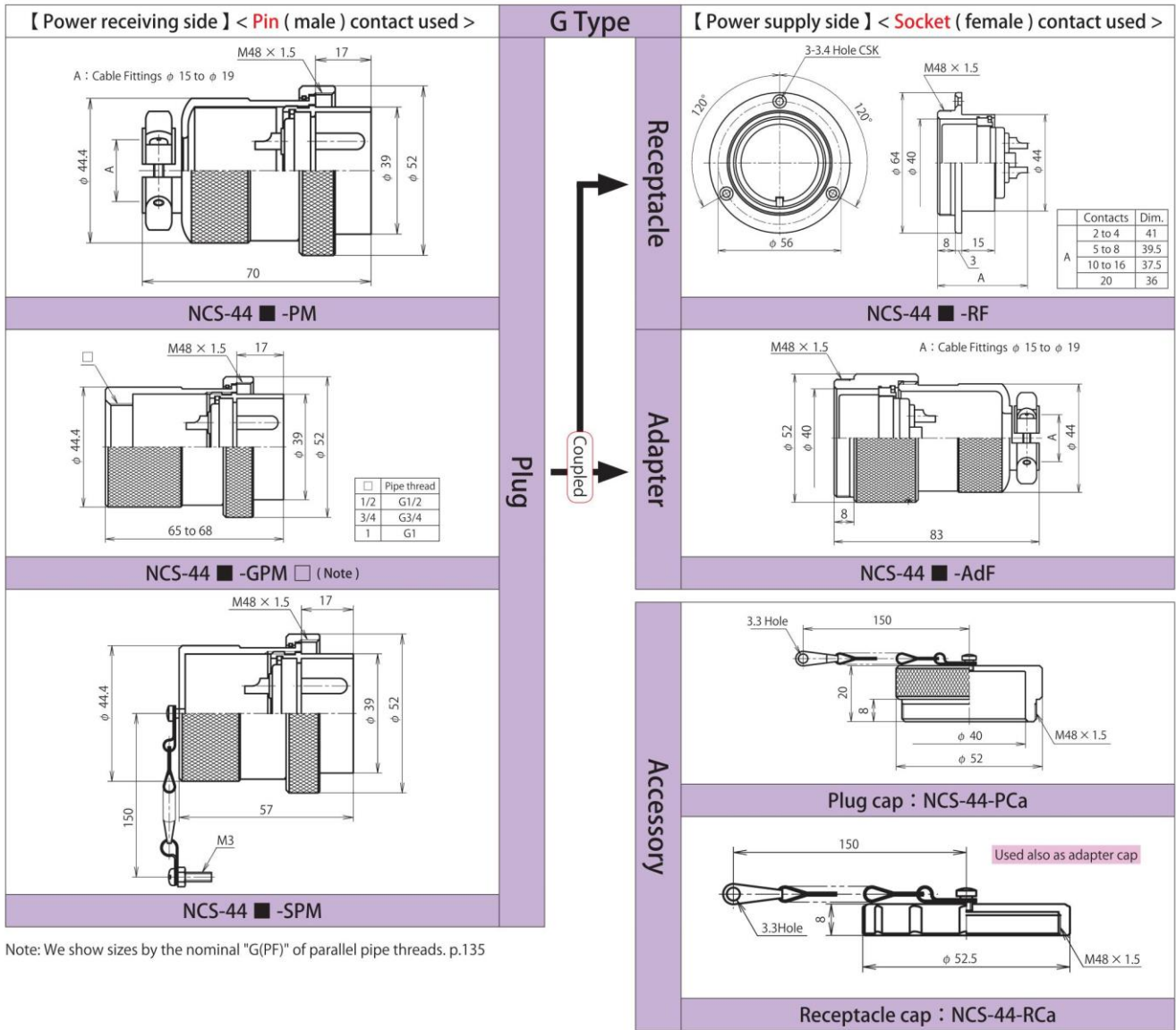

■ indicates the number of contacts.  
The conductor cross sectional area is less than the following value. However, for safety standard certified products, use a cable having a value shown on p.129.

Shell size	Number of Contacts	2	3	4	5	6	8	10	12	16	20	
44	Contact arrangement <When viewed from the pin (male) contact coupling side>											
	Safety standard (Note-1)	—					CSA NRTL/C		—			
	Rating	250V 30A				250V 20A		250V 3pcs=10A 7pcs= 5A		250V 3pcs=10A 9pcs= 5A		250V 3pcs=10A 13pcs= 5A
	Limit operating voltage (Note-2)	500V				400V		300V				
	Withstand voltage ( V r.m.s. )	2,500				2,000		1,800				
	Wire size ( mm <sup>2</sup> )	5.5						3pcs=2 7pcs=1.25		3pcs=2 9pcs=1.25		3pcs=2 13pcs=1.25

Note-1 : Specified separately. For safety standards, see p.129. ( The rated voltage of standard certified products is 265 V. ) Note-2 : For the limit operating voltage, see p.131.

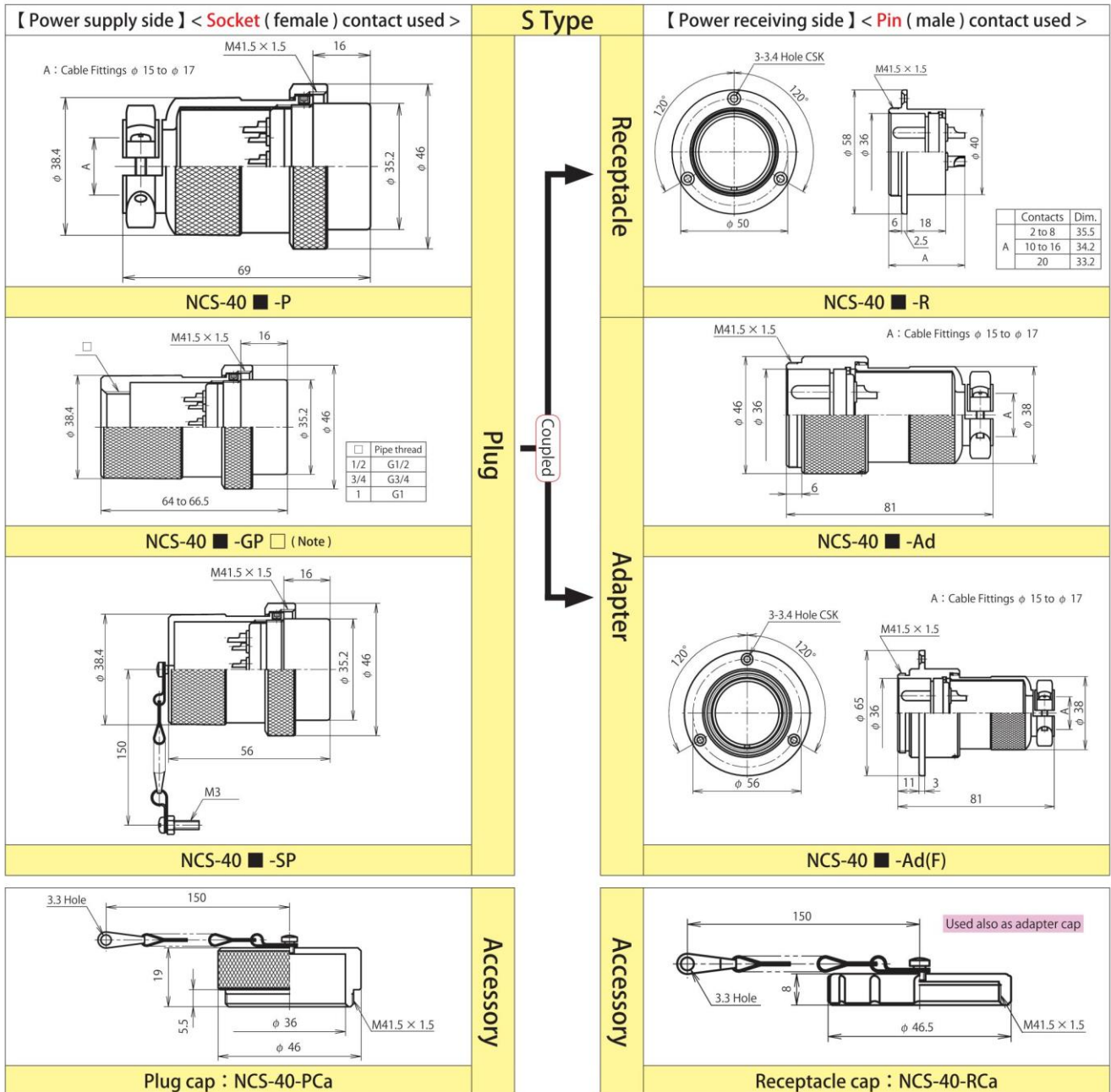

Note: We show sizes by the nominal "G(PF)" of parallel pipe threads. p.135

■ indicates the number of contacts.  
The conductor cross sectional area is less than the following value. However, for safety standard certified products, use a cable having a value shown on p.129.

Shell size	Number of Contacts	2	3	4	5	6	8	10	12	16	20	
40	Contact arrangement <When viewed from the pin (male) contact coupling side>											
	Safety standard (Note-1)	—						CSA NRTL/C	—	CSA NRTL/C		
	Rating	250V 30A				250V 20A		250V 3pcs=10A 7pcs= 5A		250V 3pcs=10A 9pcs= 5A	250V 3pcs=10A 13pcs= 5A	250V 5A
	Limit operating voltage (Note-2)	500V				400V		300V				
	Withstand voltage (V r.m.s.)	2,500				2,000		1,800				
	Wire size (mm <sup>2</sup> )	5.5						3pcs=2 7pcs=1.25		3pcs=2 9pcs=1.25	3pcs=2 13pcs=1.25	1.25

Note-1 : Specified separately. For safety standards, see p.129. ( The rated voltage of standard certified products is 265 V. ) Note-2 : For the limit operating voltage, see p.131.

# NCS Series Shell Size 54

**【 Power receiving side 】 < Pin ( male ) contact used >**

**NCS-54 ■ -PM**

**NCS-54 ■ -GPM □ (Note)**

**NCS-54 ■ -SPM**

**G Type**

Plug

Receptacle

Adapter

Accessory

**【 Power supply side 】 < Socket ( female ) contact used >**

**NCS-54 ■ -RF**

**NCS-54 ■ -AdF**

**Plug cap : NCS-54-PCa**

**Receptacle cap : NCS-54-RCa**

Coupled

Note: We show sizes by the nominal "G(PF)" of parallel pipe threads. p.135

■ indicates the number of contacts.  
The conductor cross sectional area is less than the following value. However, for safety standard certified products, use a cable having a value shown on p.129.

Shell size	Number of Contacts	2	3	4	8	10	15	25	
54	Contact arrangement <When viewed from the pin (male) contact coupling side>								
	Safety standard (Note-1)	—						CSA NRTL/C	
	Rating	500V 80A	250V 50A	250V 25A	250V 20A	250V 15A	250V 4pcs=15A 21pcs= 5A		
	Limit operating voltage (Note-2)	600V	500V	400V	300V				
	Withstand voltage (V r.m.s.)	3,000	2,500	2,000				1,800	
	Wire size (mm <sup>2</sup> )	30	14	3.5				4pcs=3.5 21pcs=2	

Note-1 : Specified separately. For safety standards, see p.129. (The rated voltage of standard certified products is 265 V.) Note-2: For the limit operating voltage, see p.131.

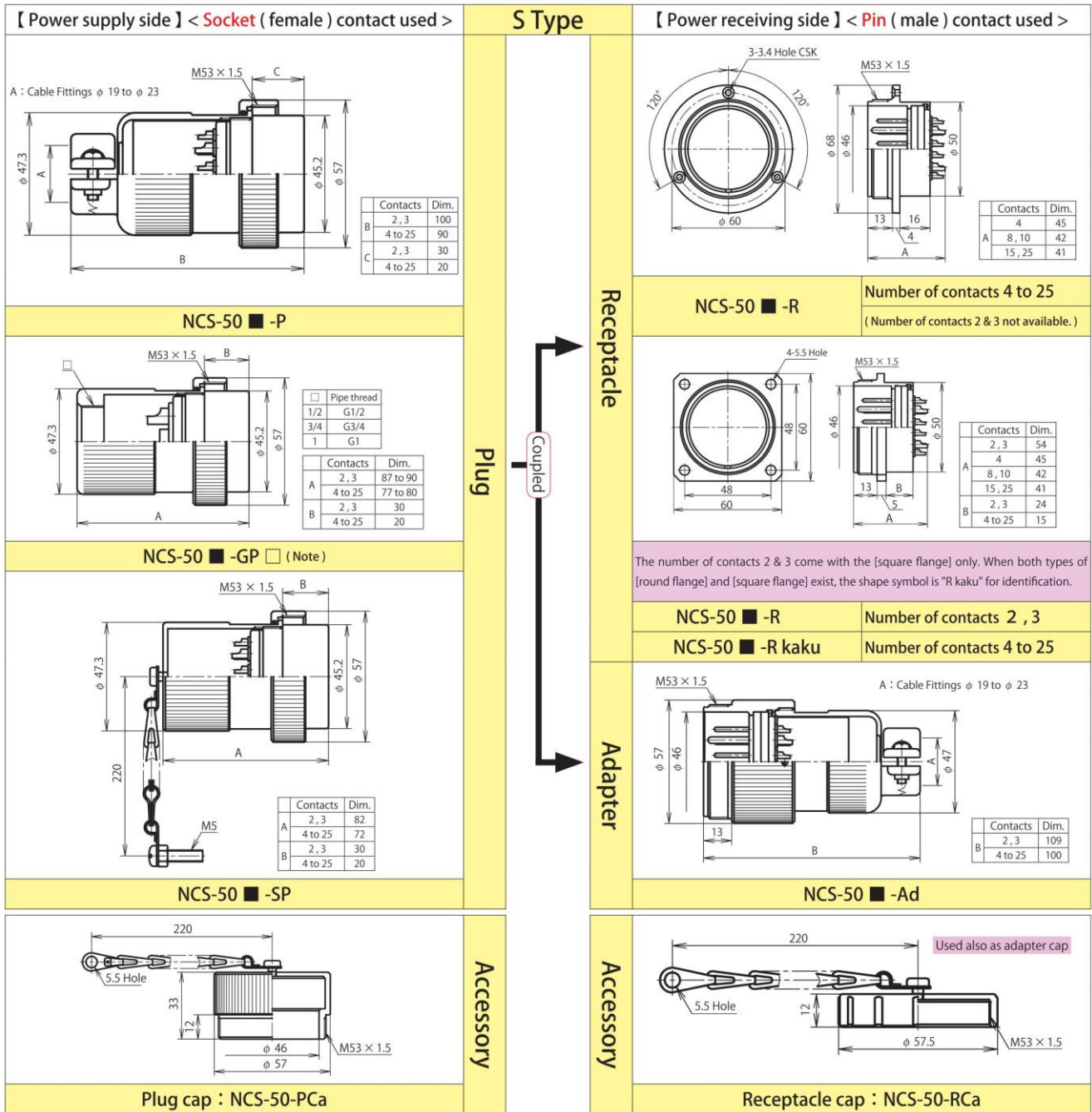

Note: We show sizes by the nominal "G(PF)" of parallel pipe threads. p.135

■ indicates the number of contacts.

The conductor cross sectional area is less than the following value. However, for safety standard certified products, use a cable having a value shown on p.129.

Shell size	Number of Contacts	2	3	4	8	10	15	25	
50	Contact arrangement <When viewed from the pin (male) contact coupling side>								
	Safety standard ( Note-1 )	—						CSA NRTL/C	
	Rating	500V 80A	250V 50A	250V 25A	250V 20A	250V 15A	250V 4pcs=15A 21pcs= 5A		
	Limit operating voltage ( Note-2 )	600V	500V	400V	300V				
	Withstand voltage ( V r.m.s. )	3,000	2,500	2,000				1,800	
	Wire size ( mm <sup>2</sup> )	30	14	3.5				4pcs=3.5 21pcs=2	

Note-1 : Specified separately. For safety standards, see p.129. ( The rated voltage of standard certified products is 265 V. ) Note-2 : For the limit operating voltage, see p.131.

# NCS Series Shell Size 60

NCS

60

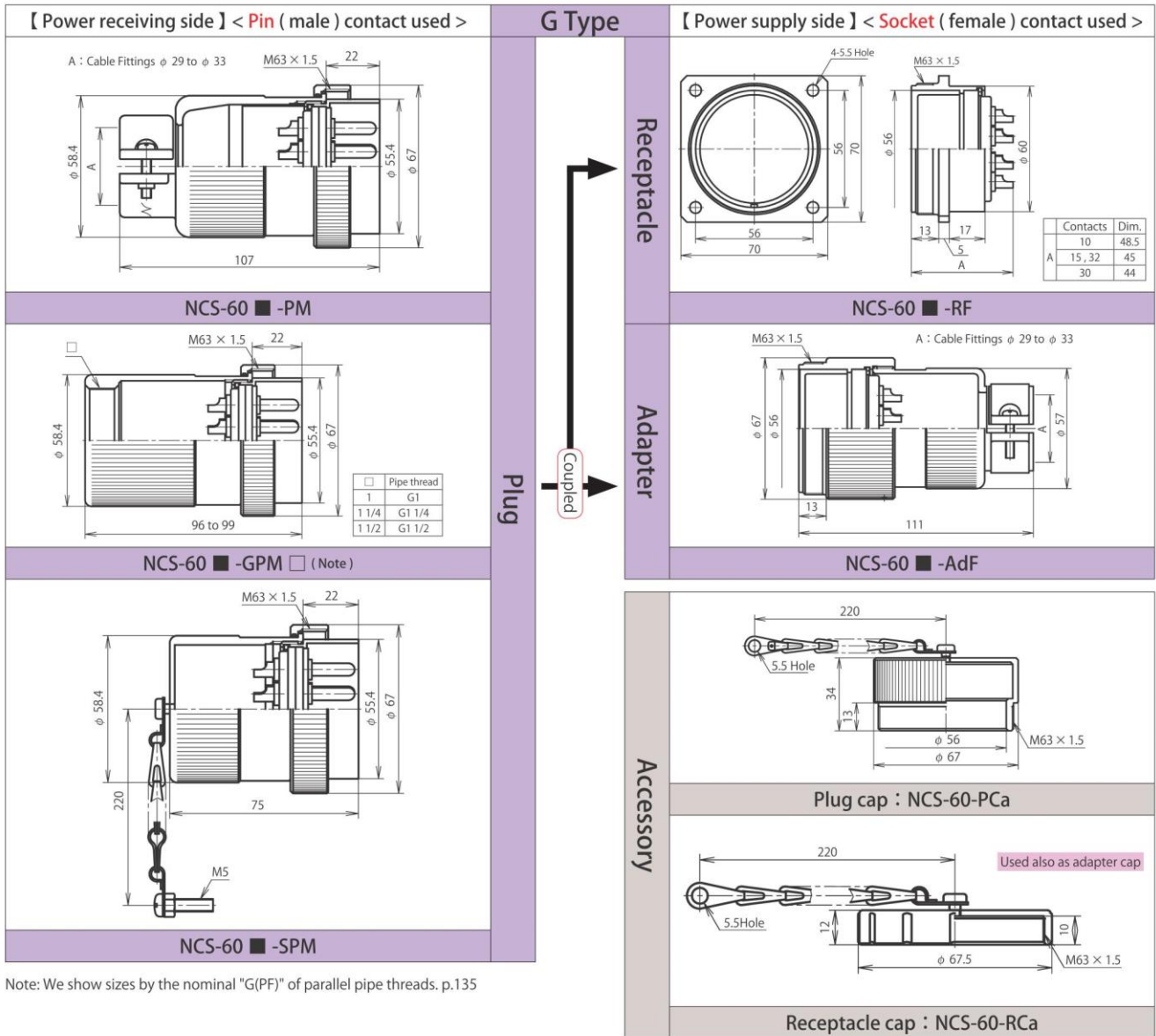

Note: We show sizes by the nominal "G(PF)" of parallel pipe threads. p.135

2-, 3- and 4-core types are available in Shell size 64.

■ indicates the number of contacts. The conductor cross sectional area is less than the following value.

Shell size	Number of Contacts	10	15	30	32
60	Contact arrangement <When viewed from the pin (male) contact coupling side>				
	Safety standard	-			
	Rating	250V 30A	250V 15A	250V 5A	250V 3pcs=15A 29pcs=5A
	Limit operating voltage (Note-1)	300V			
	Withstand voltage (V r.m.s.)	2,000		1,500	
Wire size (mm <sup>2</sup> )	8	3.5	2	3pcs=3.5 29pcs=2	

Note-1 : For the limit operating voltage, see p.131.

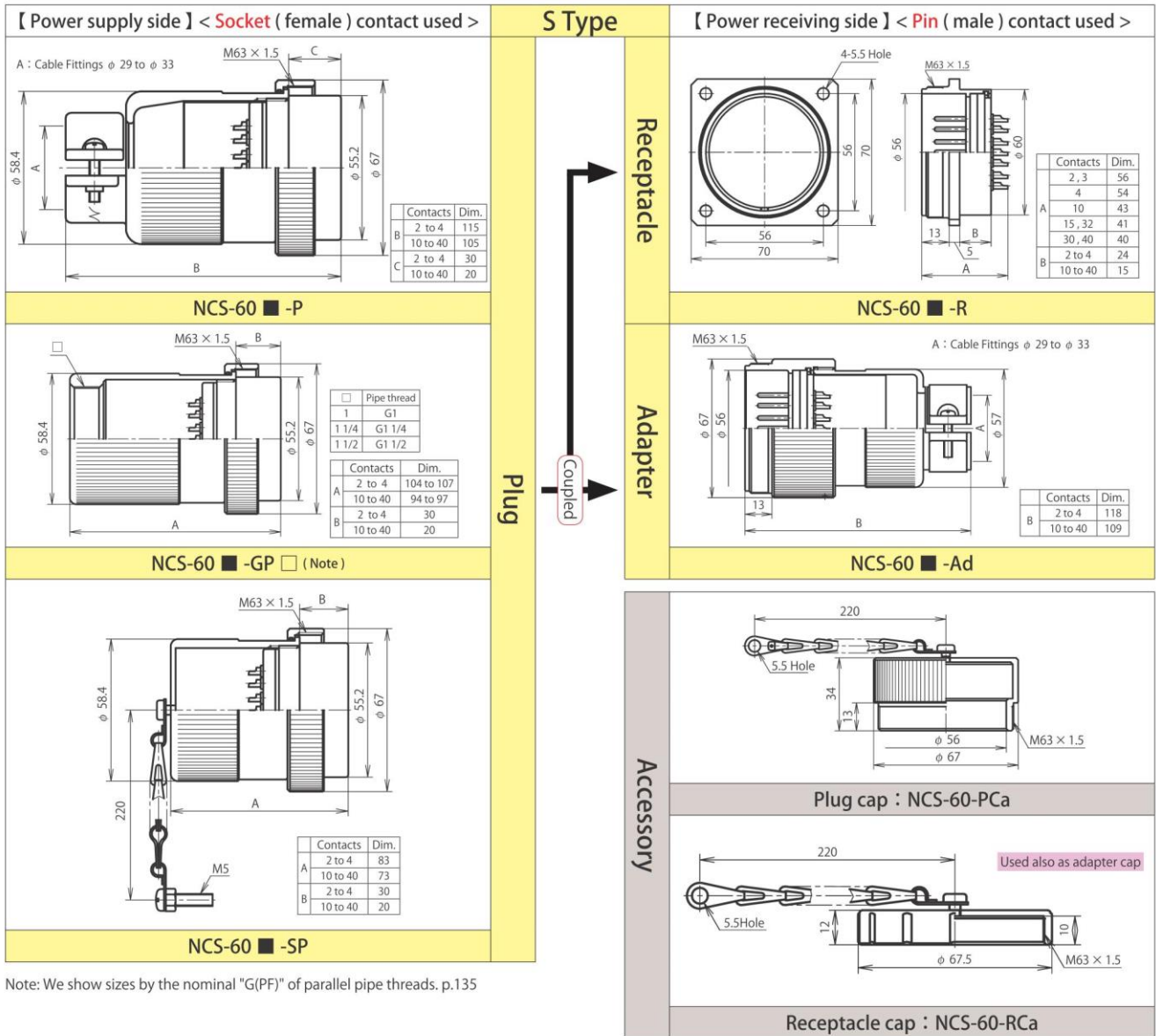

■ indicates the number of contacts. The conductor cross sectional area is less than the following value.

Shell size	Number of Contacts	2	3	4	10	15	30	32	40
60	Contact arrangement <When viewed from the pin (male) contact coupling side>								
	Safety standard	—							
	Rating	500V 150A	500V 80A	250V 30A	250V 15A	250V 5A	250V 5A	3pcs=15A 29pcs=5A	250V 5A
	Limit operating voltage (Note-1)	600V				300V			
	Withstand voltage (V r.m.s.)	3,000				2,500		1,800	
Wire size (mm <sup>2</sup> )	50	30	8	3.5	2	3pcs=3.5 29pcs=2	2		

Note-1 : For the limit operating voltage, see p.131.



# NCS Series Shell Size 64

NCS

64

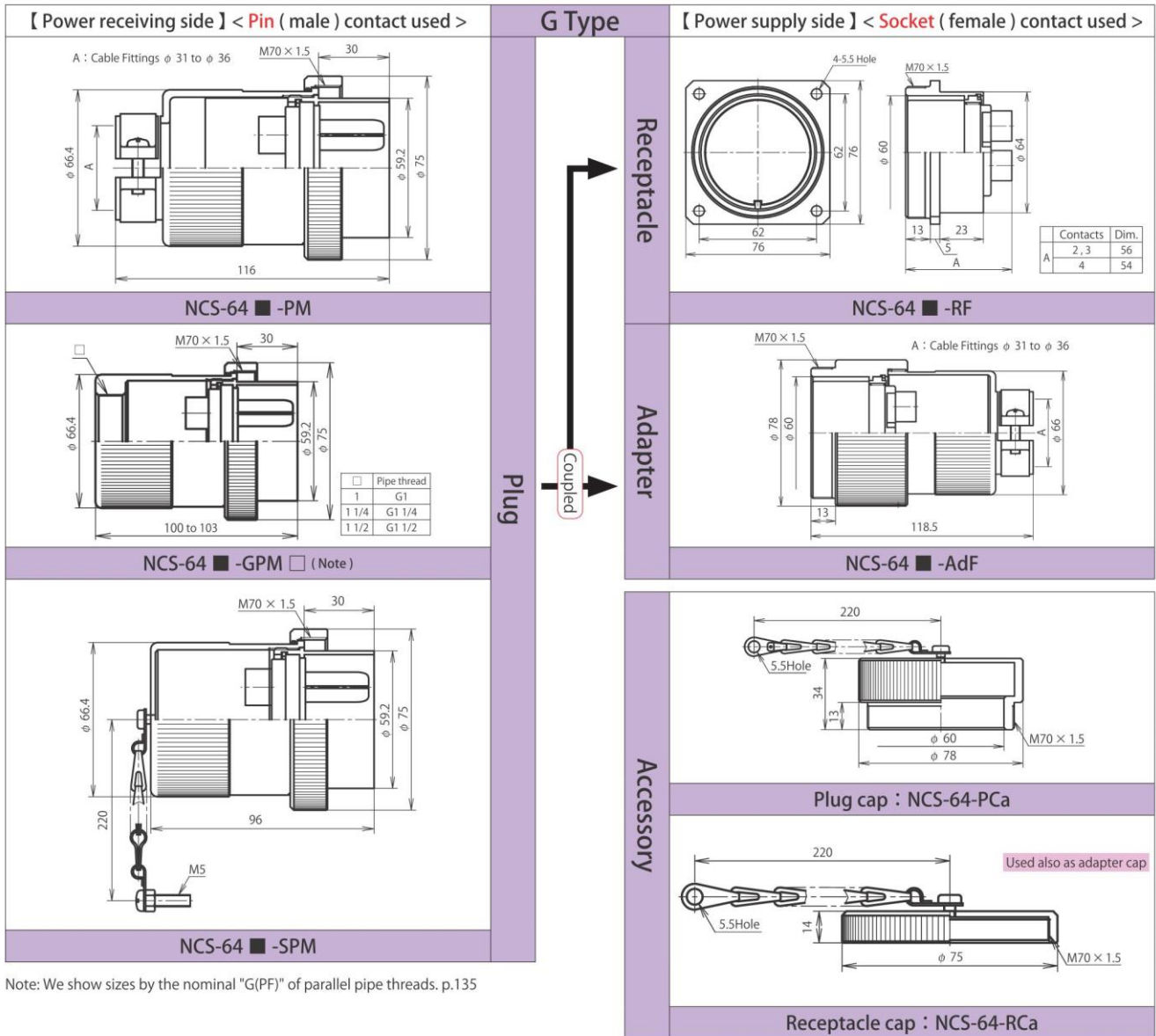

Note: We show sizes by the nominal "G(PF)" of parallel pipe threads. p.135

■ indicates the number of contacts. The conductor cross sectional area is less than the following value.

Shell size	Number of Contacts	2	3	4
64	Contact arrangement <When viewed from the pin (male) contact coupling side>			
	Safety standard	—		
	Rating	500V 150A		500V 80A
	Limit operating voltage (Note-1)	600V		
	Withstand voltage (V r.m.s.)	3,000		
	Wire size (mm <sup>2</sup> )	50		30

Note-1 : For the limit operating voltage, see p.131.